

***ISIMET* ITC-3 Integration Time Controller Solenoid Enclosure**

Installation, Maintenance, and Operation Instructions



The *ISIMET* ITC-3 operates as a single output controller incorporating a general service solenoid valve assembly along with the digital switching mechanism within a single enclosure. An internal junction box houses the 120-vac line voltage along with transformer, timer and circuit board.

Table of Contents:	
	<u>Page</u>
Warranty	2
Model Numbers	3
Enclosure Specifications & Dimensions	3
Ball & Solenoid Valve Specifications	3
Installing the Enclosure - Figures 1 & 2	4
Piping Configurations – Figure 3	5
Inlet and Outlet Fittings – Figure 4	6
Piping and Maintenance Information	6
Enclosure Piping Connections – Figure 5	7
Wiring Information	7
Wiring Schematic – Figure 6	8
Internal Junction Box – Figure 7	8
Timer Settings – Figure 8	9
Removing and Re-installing Door Panel	10
Operation of the Service Panel	11
Routine Maintenance.....	11

ISIMET

Integration Time Controller
Installation, Maintenance, and Operations Instructions

Copyright © 2015 **ISIMET/MAPA, LLC**.
All rights reserved.
Patent 6,757,589 B1
6,990,393 B2

This document is copyrighted. This document may not, in whole or part, be copied, duplicated, reproduced, translated, electronically stored, or reduced to machine readable form without prior written consent from **ISIMET**.

Although the material contained herein has been carefully reviewed, **ISIMET** does not warrant it to be free of errors or omissions. **ISIMET** reserves the right to make corrections, updates, revisions, or changes to the information contained herein.

ISIMET is a trademark of **ISIMET/MAPA, LLC**, an affiliate of **WCM Industries, Inc.**

Warranty:

ISIMET will repair or replace any defective parts or workmanship of this product for a period of one year from date of installation. The P.C. Board has a two year limited warranty. Damage caused by incorrect installation or improper usage is not warranted. Failure to follow recommended installation, operation, and/or maintenance procedures listed in this manual may void product warranty. Recovery rights shall be limited to the total sum of the amounts paid for the product by the purchaser.

ISIMET warrants the solenoid to be free from defects in materials or workmanship when incorporated into an **ISIMET** Control System for a period of one hundred and eighty (180) days from the date of installation by buyer. If the equipment or any part thereof becomes defective within the warranty period, the defective equipment will be replaced or credit allowed therefore at the sole option of **ISIMET**, but without credit or payment for any labor.

Damage caused by incorrect installation or improper usage is not warranted. Failure to follow recommended installation, operation, and/or maintenance procedures listed herein may void product warranty. Recovery rights shall be limited to the total sum of the amounts paid for the product by the purchaser.

General Service Solenoids: **ISIMET** cannot warrant against the effects of hard water, corrosive agents, contaminants, or debris present in the piping system or against effects of exotic or harsh substances.

Limits of Liability:

ISIMET's liability shall be limited to costs of repair or replacement parts. The Laboratory Service Panel and Utility Controller are not intended for usage other than those expressly described in this manual. **ISIMET** shall not be liable for damage or injury caused by the improper use of the product.

ISIMET does not warrant against or assume liability for failure of operation or lack of notification to secondary integrated monitoring systems. The system should be thoroughly tested and adjustments made at time of initial operation. Periodic testing should be conducted by the user to assure that all components function and operate according to specifications.

Care should be taken in the installation of this product. **ISIMET** shall not be liable for damage or injury caused from the improper installation of the product.

Warranty is Subject to Compliance with Specific Installation Requirements.

DISCLAIMER OF IMPLIED WARRANTY:

THERE ARE NO WARRANTIES THAT EXTEND BEYOND THE DESCRIPTION HEREIN. SELLER DISCLAIMS ANY IMPLIED WARRANTY OF MERCHANTABILITY OF THE GOODS OR OF THE FITNESS OF THE GOODS FOR ANY PURPOSE, AND BUYER AGREES THAT THE GOODS ARE SOLD "AS IS."

Printed in the United States of America.

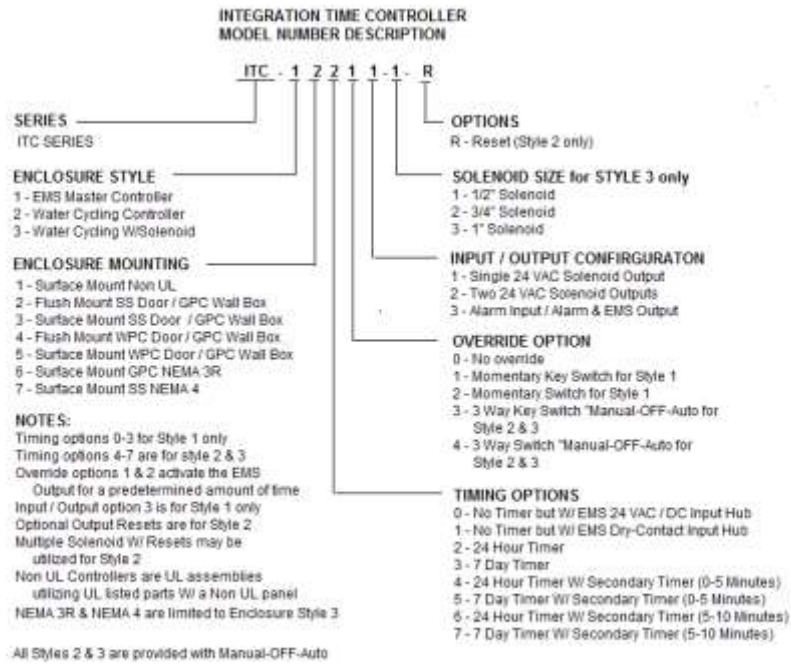

UL: Product is in compliance with the Industrial Control Panels, UL-508A Standard.

Enclosure Specifications and Dimensions:

The NEMA 1 enclosure may be either surface or flush mounted. Door is provided standard with a Key Lock. These units are not suitable for direct exposure to wet conditions but may be ordered as NEMA 4 rated with all switches and indicators mounted internally.

The valve assembly is arranged within the enclosure to insure ease in making field piping connections. Filter Ball Valves and two brass unions are provided with every assembly. Wiring leads for solenoids are terminated at the output terminal within the junction box.

Enclosure dimensions are 18X18X6

The enclosure is available in Gray Powder Coat with White Powder Coat Door and Gray Powder Coat with Brushed Stainless Steel Door.

NEMA 4 Units are 20 X 20 X 6 Gray Powder Coat. Unit is available as Surface Mount only. Switches and indicators are mounted internal. Recommended piping configuration is bottom – to – bottom.

Solenoid Valve Specifications: All solenoids are provided with 24-vac coils.

ISIMET Model	Port Size (in)	Orifice Size (in)	Min. Pressure Diff.	Flow Factor CV	Operation Pressure		24/60 VAC	
					Air/Gas psi	Water psi	VA Inrush	VA Holding
S-201	1/2	.5	2	4.8	230	230	25	14.5
S-202	3/4	.75	2	9.8	230	230	25	14.5
S-203	1	1	2	14	230	230	25	14.5
S-222	3/4	.75	2	9.8	230	230	25	14.5
S-223	1	1	2	14	230	230	25	14.5

Series 200 –General Service Brass with NBR Seat Material
Series 220 –General Service Lead Free Brass with FKM/NSF Seat Material

Maximum operating temperature for the solenoid is 180° F / 82.2° C
Coil Rating: Continuous duty totally encapsulated
Voltage Tolerances: +10%, - 10% of applicable voltage
All Solenoid Coils have a NEMA 1 Rating

Ball Valve Specifications:

Bronze 2-Piece Ball Valve. All valves are full port, bronze
“TU” – General Service Unioned & 20 mesh strainer (1/2” – 2”) 150 psi WSP 400 psi WOG

Installing the Enclosure

There are two options for mounting the Laboratory Service Panel: Flush Mounted and Surface Mounted.

CAUTION: Provided mounting hardware must be used.

Flush Mounted

Prior to installation:

- The Enclosure mounts between two standard spaced wall studs within a minimum 6" wall cavity. (See enclosure dimension – page 3)
- If stud spacing is greater than that required for the mounting of the controller, add studs to insure a secured mounting.
- The studs should be facing to facilitate securing the Enclosure.
- Predetermine wall finish so that the face lip of the enclosure aligns flush with the finished wall surface.

To install:

1. Using the self-starting screws (13), mount the flanges at each side and at the top and bottom of the enclosure.
2. Attach the enclosure to the wall studs with field-provided sheet metal screws per the drawing.
3. Level the enclosure.

Notes:

- When the Door Panel is mounted onto the Enclosure, it should protrude beyond the wall surface about 1/4". Care should be taken at installation time to ensure that this occurs.
- A Flush Mounting Trim Flange is provided with each flush mounted unit. Separate installation instructions and hardware are included with this flange.
- Semi and Flush Trim add 3.5 inches to both Height and Width wall surface dimensions.
- It is the responsibility of the installer to verify finish wall dimensions.

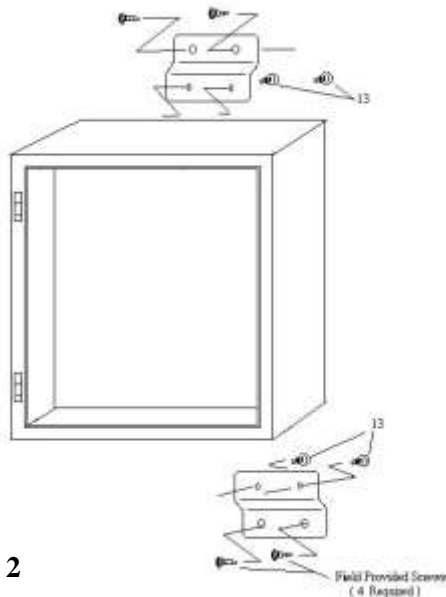
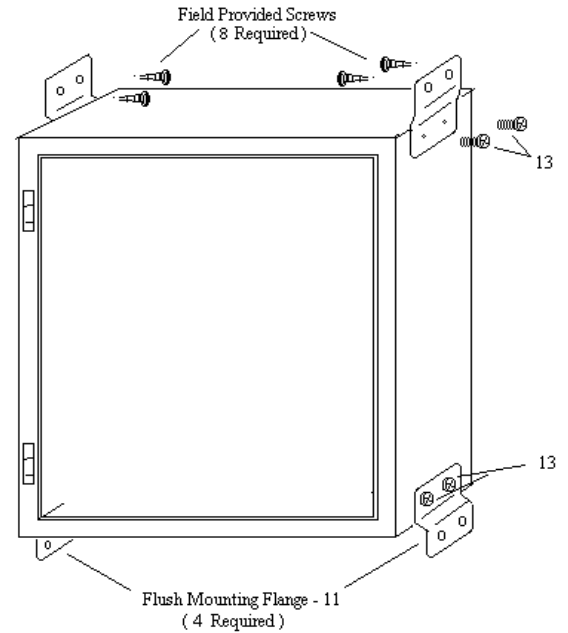

Figure 2



For best Flush Mounting results, recess face of enclosure's lip 1/2" behind wall finish

Figure 1

Semi-Recess Enclosure Placement

Note: For Semi-Recess Units, the face of the enclosure's lip should be positioned 1/4" beyond wall finish.

Clearance around Enclosure:

Care should be taken to allow 1/2" clearance from wall framing and sheet-rock or other wall surface material around the outer surface of the unit to permit the trim to be properly installed.

Surface Mounted

Prior to installation:

- Wall finishes should be complete.
- The wall cavity must have sufficient backing or support to ensure a firm mounting of the enclosure to the wall surface.

To install:

1. Secure the surface mount flanges to the back of the enclosure with the self-starting screws (13).
2. Use the field-provided screws to attach the enclosure by the flanges to the wall surface.
3. Level the enclosure.

Figure 3

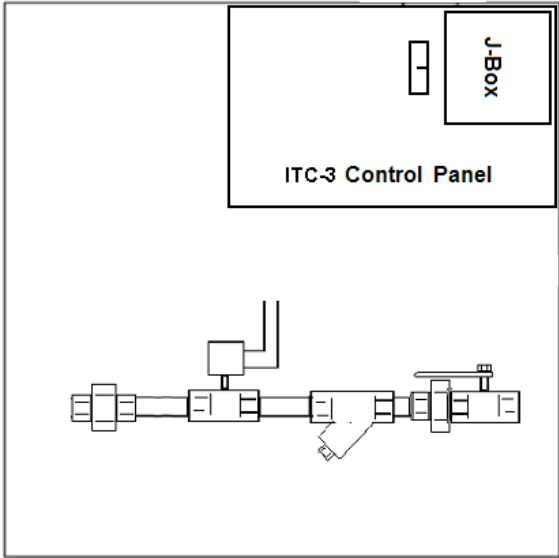

Typical Side-to-Side Solenoid Arrangement
Right – to – Left Shown
Left – to – Right Similar

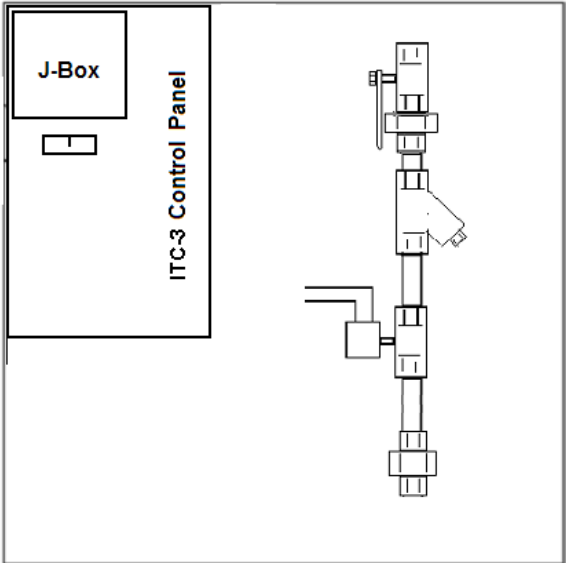

Typical Top-to-Bottom Solenoid Arrangement

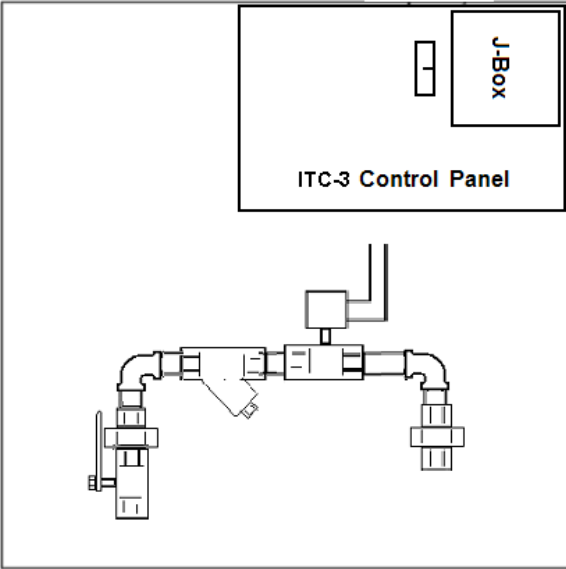

Typical Bottom-to-Bottom Solenoid Arrangement
Left – Right Shown
Right – Left Similar

Notice:

Piping system should be thoroughly flushed and cleaned prior to operation. If systems are operated without proper flushing, the solenoid diaphragm may become fouled and may not close properly when solenoid coil is disengaged. All Assemblies are provided with a Filter Ball Valve. Prior to placing the unit into operation, clean the filter on this valve. The piping joints within the enclosure should be tested to assure tight connections.

The device should only be installed by a licensed, qualified craftsman.

Parts List: (Optional bulkhead components)

“AT” Suffix - Air Tight Bulkhead Fitting
- two (2) per assembly

All assemblies use brass fittings and nipples.

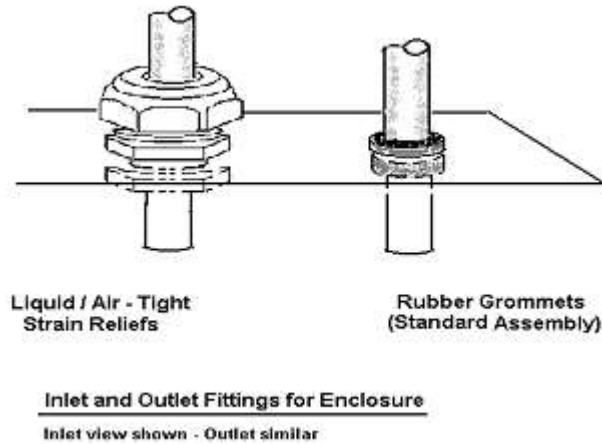

Figure 4

Inlet and Outlet Fittings Options: Inlet view shown – outlet similar

Inlet – Outlet Fittings: Two (2) sets of shown fittings for the station is provided with the enclosure dependent upon the style of enclosure specified.

Sealant/Adhesive should be applied around the attachment threads before insertion into the enclosure holes for all Air Tight and Air Tight with Vent Enclosures.

Connections to secondary containment piping should be connected to outlet end of vent fittings with interior ends left open.

Routine Maintenance: (Solenoids & Piping Systems)

Periodic examination and testing of the piping system should be performed to assure that the solenoids are functioning properly and that no foreign debris has lodged in the solenoid valve orifice, preventing the proper operation of the valve.

Caution:

Coils should not be energized unless secured to the valve core. Coils will heat during operation. A temperature of $\pm 150^{\circ}$ is not uncommon. Minimum control wire sizing is 18 AWG. Operating power wire size is 14 AWG minimum.

Enclosure Piping Connections:

When making service piping connections, provide back-up restraint at the assembly so as to prevent the turning of the valve assemblies. Disrupting the factory piping connections may cause leakage.

Care should be taken for all Air Tight and Air Tight with Vent enclosures to assure that sealant/adhesive is applied at all penetrations and that connecting fittings are made airtight.

Testing & Cleaning the Piping System:

The piping system should be thoroughly tested and cleaned of all foreign matter and debris prior to placing the enclosure into service.

The piping joints within the enclosure should be tested to assure tight connections. Do not exceed 15 psi test on any fuel gas system solenoid from upstream. Damage to the coil may result when first energized.

Installing the Electrical Conduit

Knockout holes for connecting the electrical conduits are located at the top left and side of the Enclosure.

- Connect rigid conduit for the required 120-vac electrical service to the top inlet.
- Connect conduit for second remotely located output devices at the side of the enclosure. (Dual Circuits only.)
- Connect conduit for integration input & output signal cables at the upper left side knock-out.

Electrical Specifications:

Style	# Output Circuits	Output Rating	Transformer	Relay Rating
ITC-3	1	2 amp @ 24 vac	2 amp @ 25VCT	1 @ 2 amp @ 24 vac

Caution: All local codes and regulations should be followed when installing the enclosure and making the piping and conduit connections. Only licensed, skilled craftsmen should install this unit.

Wiring the Unit:

Important! Verify that the electrical supply is disconnected prior to connecting wiring to the Service Panel.

To wire the Service Panel:

1. Remove the junction box cover.
2. A secondary Switch Box and cover is located at the top of this box. Remove this cover.
3. Make final connections to the 120-vac electrical service to wiring within the junction box (Figure 6). Verify that line wiring (Black), neutral (White), and ground wire (Green) are correctly connected. Minimum recommended wire size is 14 AWG.
4. Replace this cover before activating or testing the unit.
5. The solenoid coil is pre-wired to output terminal, posts 1 & 3 on the PC Board. Verify that wiring has not become disconnected during installation.

DO NOT route wiring to or from Input or Monitoring Circuits within conduit containing either 120-vac line or 24-vac control wiring operating a controlled inductive load. Failure to comply with these wiring specifics may create transient voltage at the pc board and cause system malfunction and/or failure.

The device should only be installed by a licensed, qualified craftsman.

Figure 5

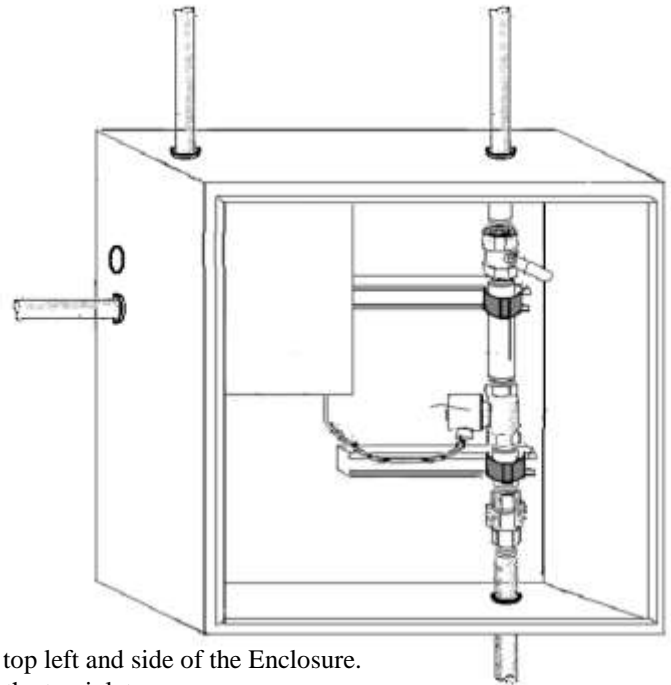

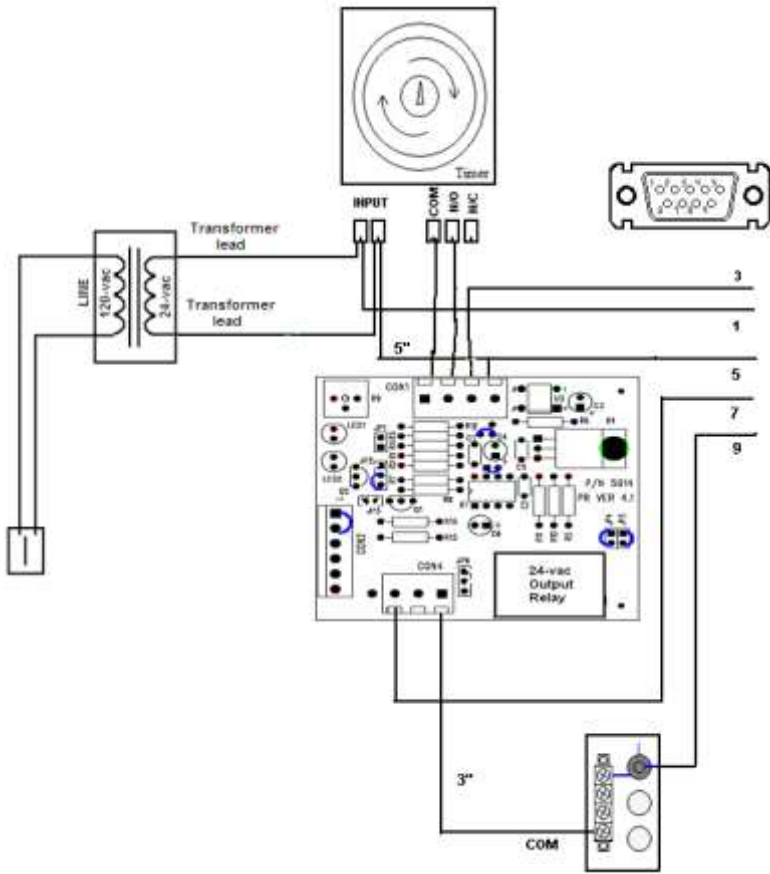

Figure 6
Wiring Schematic

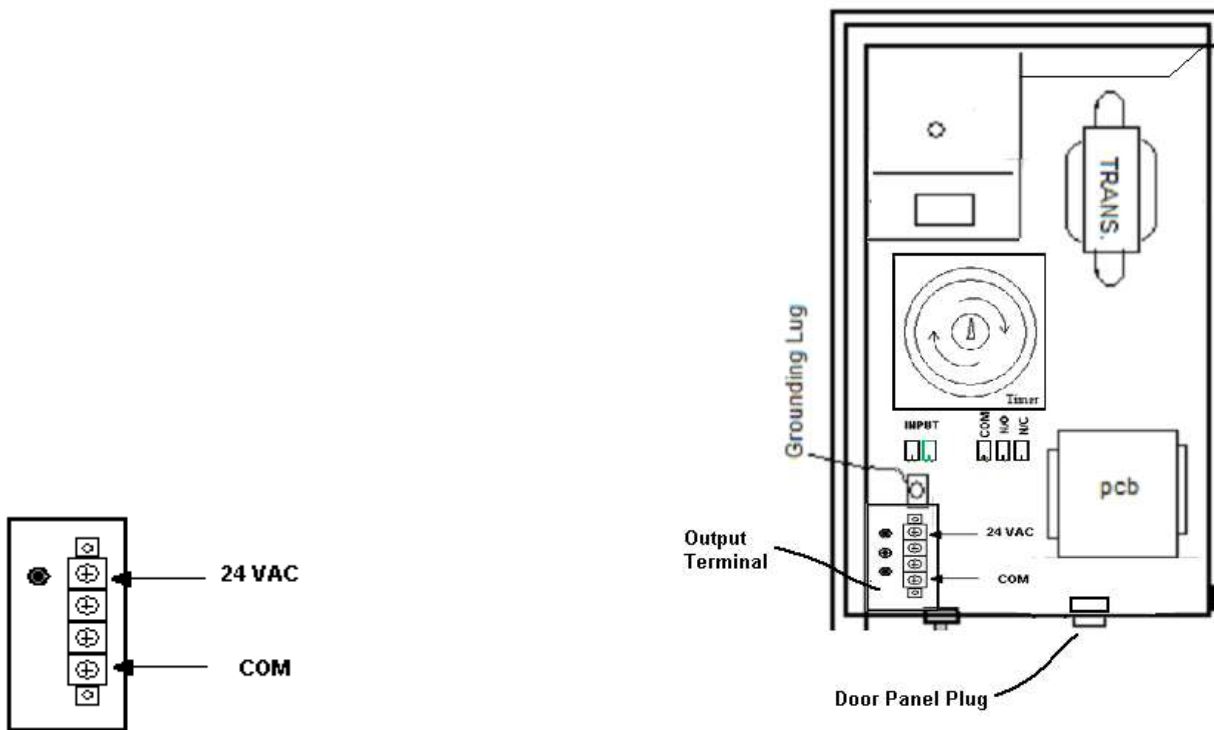

Figure 7-a
Output Terminal Wiring.

Figure 7
Internal Junction Box



**7 Day
Timer**



**24 Hour
Timer**

TIME SETTING FOR TIMER 1

If the Timer is a 7 Day Timer, to set the current time, turn the minute hand clockwise until the day of the week and the time of day on the outer dial is aligned with the triangle marker on the inner dial. If a 24 Hour Timer, turn the minute hand clockwise to the correct time. DO NOT set the time by rotating the “OUTER” Dial.

The hourly program dial reflects the hours of the day, AM/PM imprints for each day, and is settable in 15 minute increments

PROGRAMMING the TIMER

The time switch is programmed by pushing the captive trippers to the outer ring position for the entire period that the “EMS” output signal is to be turned “ON” in 15-minute increments. When the tripper is pushed to the inside, Output signal is “OFF”. The timer is preset at the factory to the beginning of a fifteen minute period each two hour period.

Example: Set the trippers for the start of each normal purge period to the “ON” position (pushed to outside). The Timer PCB will start on this signal.

Time Settings:

Timing PCB Setting is from 0 – 5 minutes with a typical factory setting of 1 minute unless customer specified otherwise. The relay may be set for any interval either between 0 and 5 minutes or 5 and 10 minutes based on specific model number. It is not recommended that field adjustments other than those stated here be made. Please contact ISIMET if changes to other relay settings are desired. To adjust time delay setting, adjust the dial on the PCB using a small flat tip screwdriver. Moving the dial in a clockwise direction will increase the ON time, see Figure 8. Timing sequence begins upon receipt of signal from Timer 1.

Figure 8

Adjust timing here.
Adjustments made in a
clockwise manner will result in
a longer delay time.

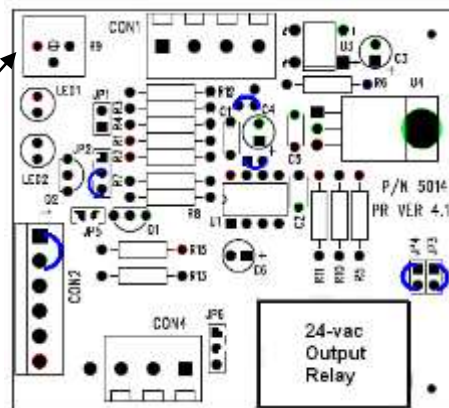

Removing and Re-installing the Door Panel

CAUTION: Before removing the door panel, unplug the door panel from the receptacle at the base of the junction box.
To install the Door Panel on the Enclosure:

1. Position the door at 90° – 100° of enclosure.
2. Slide top hinge pin onto fixed hinge post at top of door.
3. Slide lower hinge pin toward lower spring hinge mechanism with hinge pin lever in retract position.
4. With lower hinge pin in position, turn hinge pin lever outward and down, then turn inward to the extended lock position.
5. When re-installing the door, make sure that the door panel plug is securely inserted into the plug receptacle located at the base of the internal junction box.

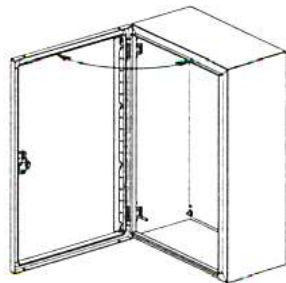

STEP 1



STEP 2

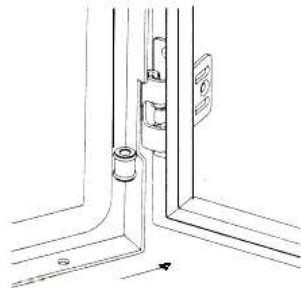

STEP 3

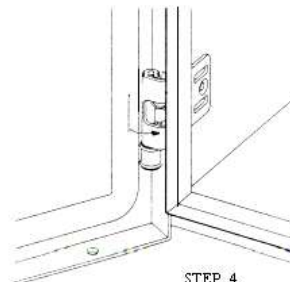

STEP 4

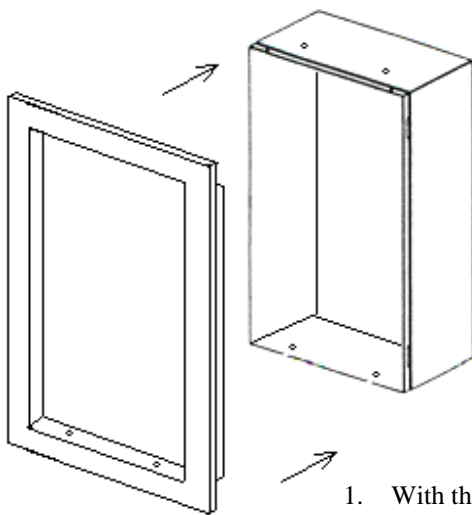

Installing the Flush Door Trim

Prior to installing Door Trim, ensure that wall finishes are complete and that the door panel has been installed.

To install the Flush Door Trim:

1. With the door in the open position, slide flush door trim over enclosure.
2. Align holes on enclosure with upper and lower holes in door trim.
3. Insert four (4) 12-24 (provided) screws through enclosure panel and tighten into door trim.

Note: Apply Sealant/Adhesive to trim screws at surface of Enclosure at each mounting hole for all Air / Water Tight Enclosures.

Operation of the Unit:

Keep the enclosure's door closed and locked during normal operation.

CAUTION: The door panel 3-way switch should be at the OFF position.

Insert the key provided with the unit into the key power switch on the door panel. Turn this key switch to the ON position. The unit will activate and the panel Green indicator will illuminate to indicate that the service is active.

Turn the 3-way switch to the MANUAL position. The solenoid should be open and the Orange indicator should illuminate.

Turn the 3-way switch to the OFF position. The solenoid should close.

Check the settings on the Primary Timer to assure operation during desired period(s).

Verify that the Secondary Timer PCB is set for the desired timing to operate. The factory setting range should be either 0 – 5 min. or 5 – 10 min. Using a small screw driver adjust the variable resistor on the circuit board to the desired operating time.

It is recommended that if intended for operation the switch remain in the “AUTOMATIC” position, except when additional purging is needed or no operation is desired.

Equipment Maintenance

- ❑ The ITC (Integration Time Controller) should have semi-annual inspections..
- ❑ *ISIMET* recommends that you periodically conduct a brief test of the system to verify that the output circuit performs as intended.
- ❑ If examination of the unit indicates tampering, *ISIMET* recommends that you first review the installation and wiring portions of this manual prior to placing the unit in service.
- ❑ *ISIMET* recommends that when solenoids are operated by the unit that the piping systems be thoroughly flushed and cleaned, and tested for leaks prior to placing the system in use. Periodic testing of these solenoids will assure that the piping system continues to function properly.

If you have any questions regarding the operation and maintenance of the unit, please contact an *ISIMET* Service Representative.

Care of the Unit

The enclosure has a NEMA 1 rating. It is not intended for use in wet areas. Exercise caution to prevent exposure of the interior compartment of the enclosure to moisture. If moisture is present within the enclosure, *ISIMET* recommends that the control switch be turned OFF, power be disconnected from the unit until the source of the moisture is determined, and all moisture is removed from the compartment.

The electronic controller (PCB) is sensitive to dust and other air-borne particles. Do not expose the interior compartment of the enclosure to dust. During the semi-annual inspection, if dust or other material is present, *ISIMET* recommends that you remove all foreign matter before operating the unit.

If the Unit fails to operate, we recommend that you check the power supply to the unit. With the control switch in the ON position, green panel indicator should be illuminated. If not, check the service breaker.

If the service switch/breaker is not damaged, and the unit still does not function, contact *ISIMET* or your local Service Representative.

Caution:

Coils should not be energized unless secured to the valve core. Coils will heat during operation. A temperature of $\pm 150^{\circ}$ is not uncommon. Power to the solenoids should be turned OFF when utilities are not in service.

General Service Solenoids: Where adverse or harsh operating conditions exist in the water system such as the presence of hard water, then it is recommended that only stainless steel valves be utilized and that an extensive routine operating and maintenance program be developed by the end user to counter the effects of these conditions. Where operation of water containing corrosive agents, exotic or harsh mediums are intended for control by solenoid then verify application prior to installation. ISIMET cannot warrant against the effects of hard water, corrosive agents, contaminants, or debris present in the piping system or against effects of exotic or harsh substances. If specific operating conditions are in doubt, contact ISIMET prior to installation.



ISIMET/MAPA, LLC

**103 W. CJ Wise Parkway
PO Box 129 (Mailing)
Naples, TX 75568**

**Phone (903) 897-0737
Fax (903) 897-0740**

www.ISIMET.com