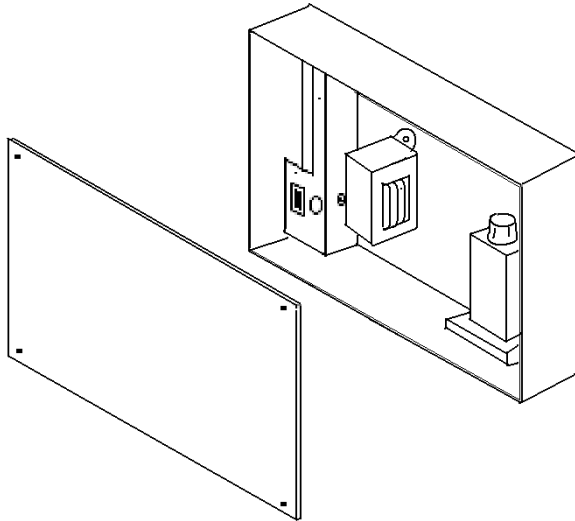

**Model LA – 4100****Time Delay “OFF” Controller****Installation,  
Operation and  
Maintenance  
Manual****Application:**

The Time Delay “OFF” Controller operates as a single output controller where the application requires restrictive activation of a utility with a delay “OFF” after first activation.

This unit is ideally suited for facilities where operation or use of water or other services is to be limited to specific time periods, where operation “ON” can be established by authority.

The delay “OFF” cycles provides a settable time from 1 minute to 2.5 hours operating cycle. It is housed in a remotely located enclosure with screw-on cover. The active “ON” switching incorporates a momentary key-switch for Operation and a push-button “STOP” switch for immediate deactivation and are mounted on a stainless steel faceplate.

**Features: Switch Panel**

Operation - Key Switch: Momentary switch for an “ON” Cycle.

Push Button Switch: Contacts disengage the system-requiring Re-keying to active “ON”.

Wall Panel: 6 X 6 Flush Mount Stainless Steel Panel with vandal resistive hardware.

(Labeling: “OPERATE” – “ON” – “STOP”)

Switch Wall Box: 5 X 5 X 3 powder coat with hardware for flush mounting.

Controller Wall Box: Powder coat mounting hardware.

**Specifications: LA 4100 Controller**

LA-4100 Series Wall Panel (Standard)

6 X 12.25 Solid Surface Mount Style Gray Powder Coat Screw Panel

Wall Box – 16 gauge powder coated sheet metal 6.0 X 12.25 X 4.0

Wall Box is provided with a surface wall mounting flange and hardware.

\* all dimensions are in inches

ISIMET  
LA Series Utility Controller – Time Delay “OFF”  
Installation, Maintenance, Operations, and Startup Instructions.  
Copyright © 2015 ISIMET/MAPA, LLC All rights reserved.

**ISIMET** is a trademark of **ISIMET/MAPA, LLC**, an affiliate of **WCM Industries, Inc.**  
This document is copyrighted. This document may not, in whole or part, be copied, duplicated, reproduced, translated, electronically stored, or reduced to machine readable form without prior written consent from **ISIMET**.

Although the material contained herein has been carefully reviewed, **ISIMET** does not warrant it to be free of errors or omissions. **ISIMET** reserves the right to make corrections, updates, revisions, or changes to the information contained herein.

**Warranty:**

*ISIMET* will repair or replace any defective parts or workmanship of this product for a period of one year from date of installation. The Primary Operating P.C. Board has a two year limited warranty. Damage caused by incorrect installation or improper usage is not warranted. Failure to follow recommended installation, operation, and/or maintenance procedures listed in this manual may void product warranty. Recovery rights shall be limited to the total sum of the amounts paid for the product by the purchaser.

**Limits of Liability:**

*ISIMET's* liability shall be limited to costs of repair or replacement parts. The Laboratory Service Panel and Utility Controller are not intended for usage other than those expressly described in this manual. *ISIMET* shall not be liable for damage or injury caused by the improper use of the product.

*ISIMET* does not warrant against or assume liability for failure of operation or lack of notification to secondary integrated monitoring systems. The system should be thoroughly tested and adjustments made at time of initial operation. Periodic testing should be conducted by the user to assure that all components function and operate according to specifications.

Care should be taken in the installation of this product. *ISIMET* shall not be liable for damage or injury caused from the improper installation of the product.

Warranty is Subject to Compliance with Specific Installation Requirements.

**EXTENDED WARRANTY:**

***ISIMET* will extend the warranty period of the products when installation complies with all start up procedures and that a factory authorized agent either performs or is in attendance during start-up of the system(s). Controllers, Companion and Accessory Panels will be extended to a period of five years from date of installation. Except for *ISIMET* FLA, DLA, RLA and other Units where automation systems are not common, Control System(s) must be interfaced with a building automation system or other *ISIMET* approved time sequencing control for “non-use” system shutdown. All operating components of the system must be *ISIMET* provided. Prescribed routine maintenance procedures must be performed per *ISIMET* recommendations.**

**All Start-up and Routine Maintenance Documentation shall be per Factory Recommendation.**

**Further, required start-up and maintenance procedures must be performed as directed upon all affected systems. This warranty shall only become enforceable upon issuance of application specific Extended Warranty Document. A copy of this document should be maintained at all times at the location of the warranted systems.**

**DISCLAIMER OF IMPLIED WARRANTY:**

**THERE ARE NO WARRANTIES THAT EXTEND BEYOND THE DESCRIPTION HEREIN. SELLER DISCLAIMS ANY IMPLIED WARRANTY OF MERCHANTABILITY OF THE GOODS OR OF THE FITNESS OF THE GOODS FOR ANY PURPOSE, AND BUYER AGREES THAT THE GOODS ARE SOLD “AS IS.”**

Printed in the United States

**Specifications:**

Switch Panel - Stainless Steel 16 gauge  
6" X 6"  
Wall Box – 16 gauge plated sheet metal  
W/Solid Screw Panel  
LA – 41 or 43 (1 Circuit) 6" X 12.25" X 4"  
Switch Panel Box 5" X 5" X 3"

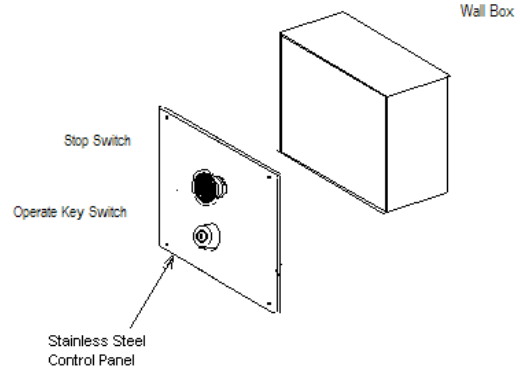

**Switch Configurations:**

- 1 – Switches Located at Flush Mounted IP-O-S-P (Standard)
- 2 – Switches Located at Surface Mounted IP-O-S-P
- 3 – Switches Located on LA-4000 Series Wall Panel

Styles	# Output Circuits	Output Rating	Transformer	Relay Rating
LA –4100 24 VAC	1	2 amp at 24 VAC	2 amp at 25VCT	1 at 2 amp at 24 VAC
LA –4300 24 VAC	1	2 amp at 24 VAC	2 amp at 25VCT	1 at 2 amp at 24 VAC

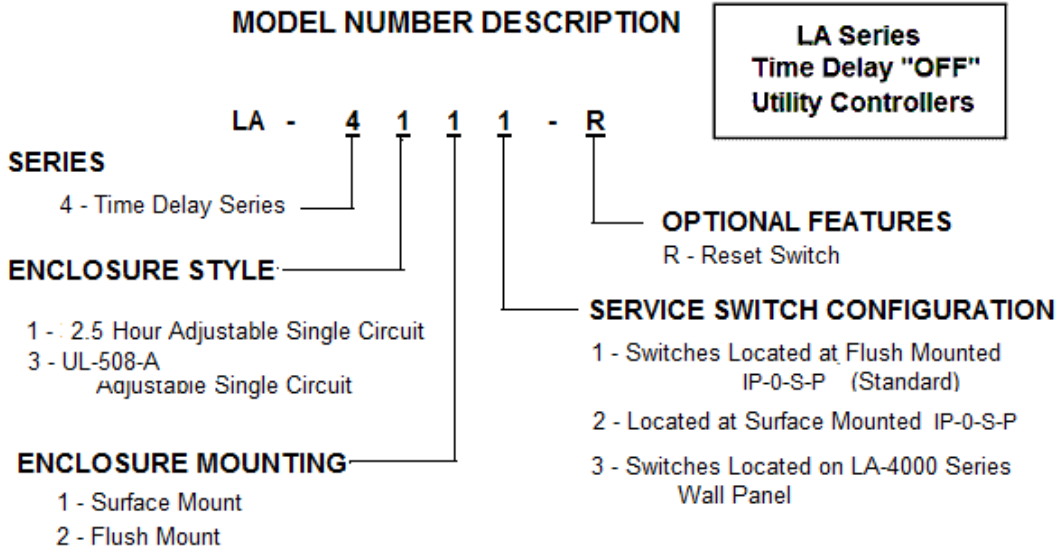

**Solenoids and Fittings Sold Separately**

**Time Delay "OFF" Settings:**

The unit has been factory set to operate for 2.5 hours upon activation. The time delay relay may be set for any interval between 0 and 2.5 hrs. Other re-programming features are available for the relay, but it is not recommended that field adjustments other than those stated here be made. Please contact ISIMET if changes to other relay settings are desired. To adjust time delay setting: 1. Remove the Controller cover. 2. Turn "OFF" power to the unit. 3. Adjust the knob atop the relay to the appropriate setting. 4. Replace cover.

**Parts List:**

- Controller Wall Box
- J-Box Panel with switch & fuse
- 2 amp transformer
- Time delay relay
- Trigger input terminal

Switch Panel with "OPERATE" key-switch and "STOP" button

Switch Wall Box with mounting hardware

**Solenoid Kit**

- 1 - Solenoid (24-VAC)
- 1 - Brass Union
- 1 - Brass Ball Valve W/ Nipples

Solenoid Kit sold separately

**Optional Accessories:**

- 1 - PPP inc. Sock-Arrestor  
W/ Brass Nipple, Elbow & Tee
- 1 - In-Line filter  
Brass y-Strainer & Nipple

**Mounting Instructions: Flush Wall Mount Controller Wall Box**

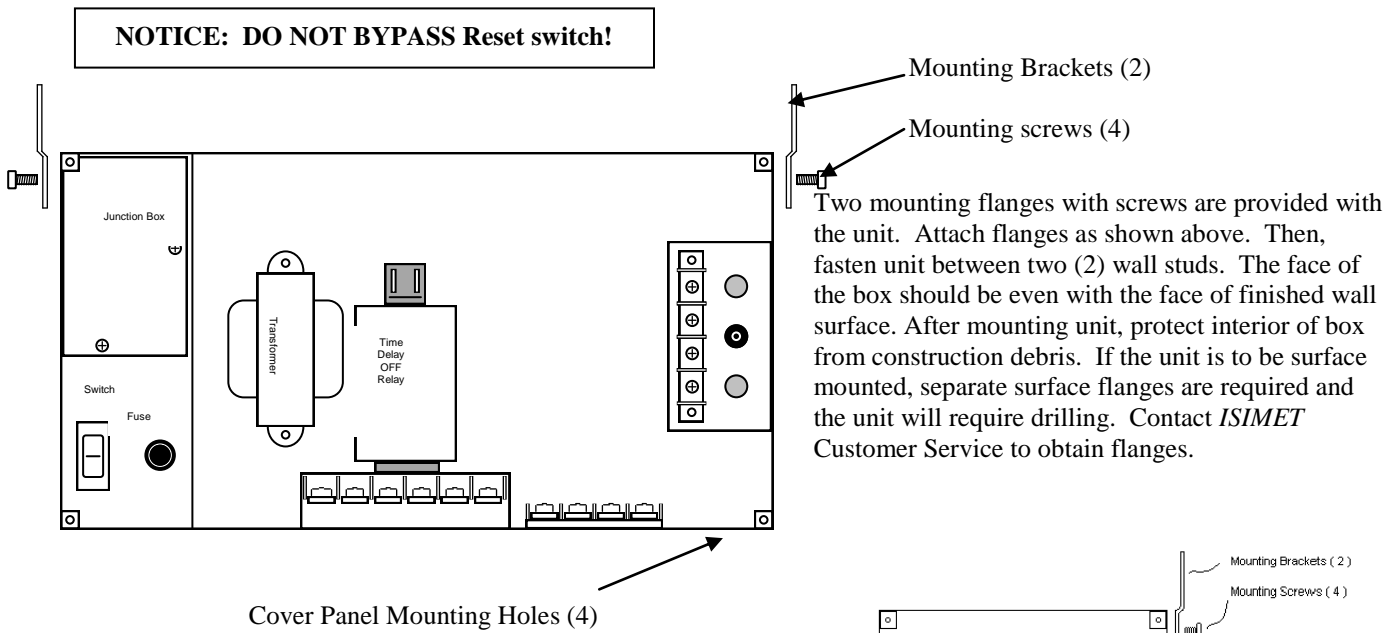

**Mounting Instructions: Flush Mount Switch Box**

Two mounting flanges with screws are provided with the unit. Attach flanges as shown above. Then, fasten unit between two (2) wall studs. The face of the box should be even with the face of finished wall surface. After mounting unit, protect interior of box from construction debris.

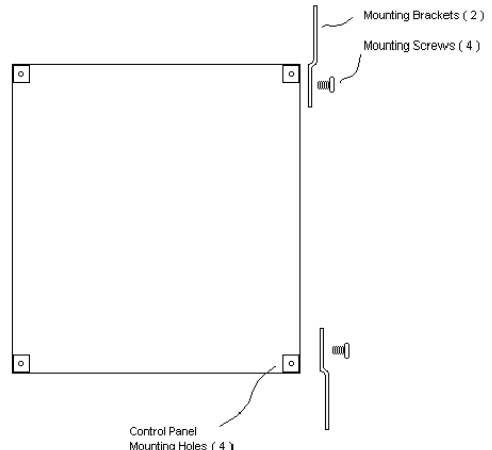

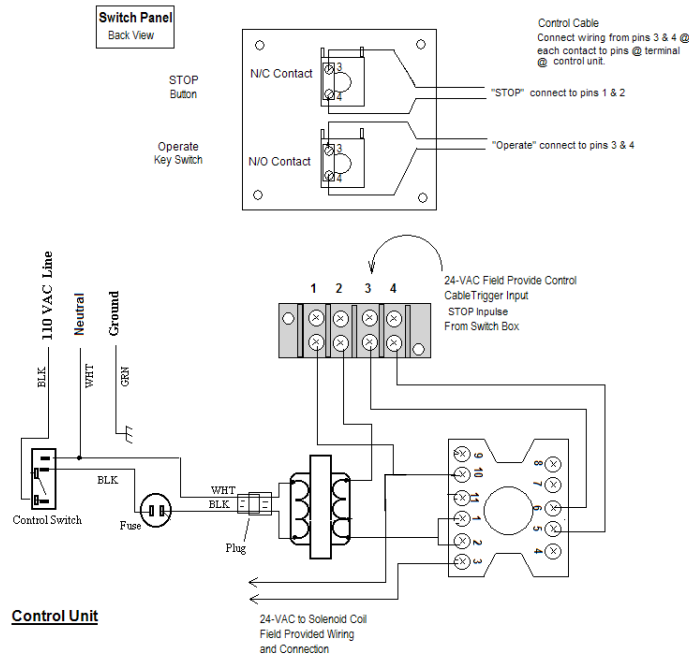

## Wiring Schematic

### Installing the Electrical Conduit

Knockout holes for connecting the electrical conduits are located at the top left and right of the Wall Box.

- Connect rigid conduit for the required 120 VAC electrical service.
- Connect conduit for the operating power to the upper left top of the enclosure at the junction box.
- Connect conduit for the operating power for the output to the upper right top of the enclosure.
- Install wiring from switch box to unit as shown (4 conductor, 18-awg min.)

## Wiring the Unit

### Important!

**Verify that the electrical supply is disconnected prior to connecting wiring to the Controller.**

To wire the Controller:

1. Remove the junction box cover.
2. Make final connections to the 120 VAC electrical service to wiring within the junction box. Verify that line wiring (Black), neutral (White), and ground wire (Green) are correctly connected. Minimum recommended wire size is 14 AWG.
3. Replace the junction box cover before activating or testing the unit.

### Connection of the Switch Panel

Route Min. 18AWG 24-VAC cabling from the Switch Panel to the Controller. Make final connections as shown.

**Note:** Refer to additional wiring schematic provided with aquastat.

### Connection of the Solenoid

Route Min. 18AWG 24-VAC cabling from the Controller to the Solenoid. Make final connections as shown.

### Important!

**All local codes must be followed when installing this unit and connecting the conduit to the service panel and making wiring connections. Do not install wiring or cable for integrated systems, remote panic assemblies or other interface wiring within conduit for either 24-vac control or 120-vac line voltage. Each wiring system should be housed in independent conduit and not bundled with wiring for other systems. Do not place this unit into operation unless the Controller Cover Panel and Switch Panel are in place. We recommend that the system be thoroughly tested prior to placing into operation.**

**Note: Only qualified craftsmen licensed within the governing jurisdiction to perform the work associated with this installation should install and/or service this equipment.**

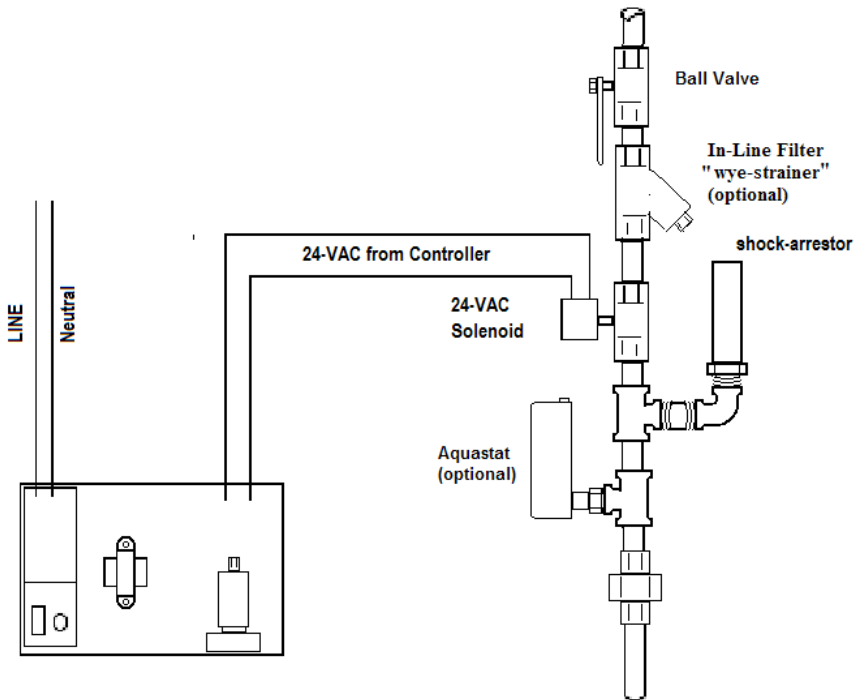

### **Solenoid Installation & Wiring Schematic**

Install Solenoid, Ball Valve, & Brass Fittings and as Shown.

Install optional Shock-Arrestor, filter & Aquastat when provided with unit as shown.

Extend field provided 24-VAC wiring (2-18 awg min.) from Controller to Solenoid. Make final wiring connections as shown.

It is recommended that wiring terminations be made at the solenoid in a weather-tite J-Box.

### **Typical 24 VAC wiring application**

#### **Installing the Switch Panel and Controller Service Panel Controller:**

- Remove protective cover from the Wall Box.
- Verify that Unit is wired with Junction box cover in place.
- Turn Power **ON**. (Verify that switch illuminates.)
- Using the provided 8-32 nylon thumb-screws, affix the cover onto the Controller box.

#### **Switch Panel:**

- Holding switch panel in front of the switch box, make wiring connections to the terminals on the switches as shown. Affix the panel to the box using the four (4) provided hex-head screws.
- Affix panel to box using four (4) 8-32 stainless screws provided with panel.

**CAUTION!** Do not install the panels until all wall finishes are complete.

#### **Operation of the Unit:**

Insert the key provided with the unit into the key switch on the switch panel. Turn the switch to the “ON” position. Release and then remove the key. The unit should activate for the pre-set time (2.5 hours factory setting or operator adjusted).

Press the “STOP” button. The unit will deactivate requiring re-keying to restart the time sequence.

We recommend that the unit be left OFF when service is not required. Do not leave the key in the unit.

## Equipment Maintenance

- ❑ The LA Series Controller should have semi-annual inspections.
- ❑ **ISIMET** recommends turning OFF the service switch when the unit is not intended for operation.
- ❑ **ISIMET** recommends that you periodically conduct a brief test of the system to verify that the output circuit performs as intended.
- ❑ If examination of the unit indicates tampering, **ISIMET** recommends that you first review the installation and wiring portions of this manual prior to placing the unit in service.
- ❑ **ISIMET** recommends that when solenoids are operated by the unit that the piping systems be thoroughly flushed and cleaned, and tested for leaks prior to placing the system into use. We recommend that an in-line filter or strainer be installed immediately up-stream of the solenoid to protect the valve from damage frequently caused by debris in the piping system. Periodic testing of these solenoids will assure that the piping system continues to function properly.

If you have any questions regarding the operation and maintenance of the LA Series Controller, please contact an **ISIMET** Service Representative

The enclosure has a NEMA 1 rating. It is not intended for use in wet areas. Exercise caution to prevent exposure of the interior compartment of the enclosure to moisture. If moisture is present within the enclosure, **ISIMET** recommends that the control switch be turned OFF, power be disconnected from the unit until the source of the moisture is determined, and all moisture is removed from the compartment.

The components including the relay and transformer are sensitive to dust and other air-borne particles. Do not expose the interior compartment of the enclosure to dust. During the semi-annual inspection, if dust or other material is present, **ISIMET** recommends that you remove all foreign matter before operating the unit.

If the Unit fails to operate, we recommend that you check the power supply to the unit. With the control switch in the ON position, it should be illuminated if power is on to the unit. If not, check the service breaker.

If the control switch is illuminated, check the fuse at fuse holder. If the fuse is not damaged and the unit still does not function, contact **ISIMET** or your local Service Representative.

If the unit still fails to operate, we recommend that you contact your local Service Representative.

### CAUTION:

**ISIMET** DOES NOT recommend that service to emergency and/or safety devices, such as emergency showers and eyewashes, be controlled by the LA Series Controller System or Solenoids. Such devices are intended to operate independent of restrictive authority operation, as is the case with the design of this unit. **ISIMET** makes available components for the monitoring of such safety devices. Please contact **ISIMET** regarding any questions regarding the type of application.



**ISIMET/ MAPA, LLC  
PO Box 129 (Mailing)  
103 W. CJ Wise Pkwy  
Naples, Texas 75568-0129**

**Phone (866) 897-0737  
Fax (903) 897-0740**

**[www.ISIMET.com](http://www.ISIMET.com)**

**Innovative Systems  
Integrating  
Mechanical and Electrical  
Technology**