

ISIMET

**UtC TOUCHSCREEN
UTILITY CONTROLLER**



**UtC/TS
Installation,
Maintenance,
Operations,
and Start-up
Instructions**



Read all instructions BEFORE installation and USE of Controller.
KEEP INSTRUCTIONS FOR FUTURE USE.

ISIMET

UtC/TS Utility Controller
Installation, Maintenance, Operations, and Startup Instructions

Copyright © 2015 ***ISIMET/MAPA, LLC***.

All rights reserved.

Patent 6,757,589 B1

6,990,393 B2

Other Patents Pending

This document is copyrighted. This document may not, in whole or part, be copied, duplicated, reproduced, translated, electronically stored, or reduced to machine readable form without prior written consent from ***ISIMET***.

Although the material contained herein has been carefully reviewed, ***ISIMET*** does not warrant it to be free of errors or omissions. ***ISIMET*** reserves the right to make corrections, updates, revisions, or changes to the information contained herein.

ISIMET is a trademark of ***ISIMET/MAPA, LLC***, an affiliate of ***WCM Industries, Inc.***

Warranty:

ISIMET will repair or replace any defective parts or workmanship of this product for a period of one year from date of installation. The Primary Operating P.C. Board has a two year limited warranty. Damage caused by incorrect installation or improper usage is not warranted. Failure to follow recommended installation, operation, and/or maintenance procedures listed in this manual may void product warranty. Recovery rights shall be limited to the total sum of the amounts paid for the product by the purchaser.

Limits of Liability:

ISIMET's liability shall be limited to costs of repair or replacement parts. The Laboratory Service Panel and Utility Controller are not intended for usage other than those expressly described in this manual. ***ISIMET*** shall not be liable for damage or injury caused by the improper use of the product.

ISIMET does not warrant against or assume liability for failure of operation or lack of notification to secondary integrated monitoring systems. The system should be thoroughly tested and adjustments made at time of initial operation. Periodic testing should be conducted by the user to assure that all components function and operate according to specifications.

Care should be taken in the installation of this product. ***ISIMET*** shall not be liable for damage or injury caused from the improper installation of the product.

Warranty is Subject to Compliance with Specific Installation Requirements.

EXTENDED WARRANTY:

ISIMET will extend the warranty period of the products when installation complies with all start up procedures and that a factory authorized agent either performs or is in attendance during start-up of the system(s). Controllers, Companion and Accessory Panels will be extended to a period of five years from date of installation. Except for ***ISIMET*** FLA, DLA, RLA and other Units where automation systems are not common, Control System(s) must be interfaced with a building automation system or other ***ISIMET*** approved time sequencing control for "non-use" system shutdown. All operating components of the system must be ***ISIMET*** provided. Prescribed routine maintenance procedures must be performed per ***ISIMET*** recommendations.

All Start-up and Routine Maintenance Documentation shall be per Factory Recommendation.

Further, required start-up and maintenance procedures must be performed as directed upon all affected systems. This warranty shall only become enforceable upon issuance of application specific Extended Warranty Document. A copy of this document should be maintained at all times at the location of the warranted systems.

DISCLAIMER OF IMPLIED WARRANTY:

THERE ARE NO WARRANTIES THAT EXTEND BEYOND THE DESCRIPTION HEREIN. SELLER DISCLAIMS ANY IMPLIED WARRANTY OF MERCHANTABILITY OF THE GOODS OR OF THE FITNESS OF THE GOODS FOR ANY PURPOSE, AND BUYER AGREES THAT THE GOODS ARE SOLD "AS IS."

Printed in the United States of America.

Table of Contents:

	Page
Warranty	2
General Product Information	4
Assembly, Compliance and Registration Information.....	4
Pre-Installation Information.....	4
Model Number Description	5
Flush Mount Installation	6
Surface Mount Installation.....	6
Installing the Electrical Conduit	7
Wiring the Utility Controller	7
Installing the Door Panel	8
Installing the Door Trim	8
PLC Overview	9
Connecting Controlled Services	10
Connecting Alarm & Monitoring Wiring	10
Start-Up Checklist	11
Start-Up Test Preliminary Information.....	11
Start-Up Test.....	12
Equipment Operation	13
Troubleshooting	14
Equipment Maintenance	15
ISIMET Contact Information.....	16

Table of Figures and Reference Tables:

	Page
Figure 1 - Model Numbers.....	5
Figure 2 - Flush Mounted Controller.....	6
Figure 3 - Surface Mounted Controller.....	6
Figure 4 - Controller Knock-Out Holes.....	7
Figure 5 - Junction Box Wiring	7
Figure 6 - Door Panel Installation.....	8
Figure 7 - Door Trim Installation.....	8
Table 1 - PLC Indicator Lights	9

General Product Information

The Utility Controller is a safety device that grants local, absolute authority to the instructor to determine those utilities that are to be used during the class-day for experiment while restricting unauthorized student use of laboratory devices. The device regulates the control of various utility services such as domestic water, natural gas, and electrical outlets within a science classroom. A Passcode provides for security against unauthorized use of the system.

Construction

All electrical components are pre-assembled, wired, and mounted. The Electronic Controller is assembled within the Utility Controller compartment.

The Utility Controller has either a brushed stainless steel or powder coat finish. All panels and enclosures are constructed of welded 14-gauge sheet metal.

Caution: Do not drop this assembly or expose it to the environment.

Assembly, Compliance and Registration Information

All Controllers are assembled to permit limited field configurations of the operating system. Options requiring additional instructions and/or assembly parts are shipped within the component package. Refer to Equipment Specifications to verify that ALL components conform to these requirements.

The output circuits of the Controller provide 24 VDC control signals to relays to activate and engage the various utilities. *ISIMET* provides a full line of Companion Enclosures and fittings. It is recommended that these items be included in the system design, but when the installer elects to provide these fittings from other sources, compliance with product specifications must be confirmed prior to installation.

Enclosed with this Manual is a separate registration form. The front of the form is for equipment warranty registration. The back is a copy of the equipment start-up checklist. To ensure proper warranty of the product, it is important that you complete both sides of the form and either mail or fax to *ISIMET* within 30 days of installation and start-up.

Locating and Positioning the Controller

Prior to installation, verify ADA (Americans with Disabilities Act) dimensions and compliance requirements. For best results: Install the Controller in the room where the utility services are controlled, at or near an exit, and accessible to occupants of the room. Mount the vertical center of the service switches on the door panel to the ADA-required maximum height.

The Door Panel and Trim Kit

The Trim Kits are packaged separately from the Utility Controller enclosure and have a protective wrapping. (Trim Kit not provided with surface mounted units.) The provided trim kit is either flush or semi-recessed. Verify installation requirements prior to installation of the unit. Store the Door Panel and Trim Kit in a protected location, out of the weather, until installation.

Install the Door Panel onto the Utility Controller after ALL other wiring connections within the controller have been made.

Upon Receipt of Product

Each Utility Controller is assembled specifically for an individual application. All primary components have the same code number.

Check components for damage. Notify *ISIMET* immediately of any damaged components. Check package and product name plates to determine if all components were shipped correctly. Store uninstalled components in a protected environment, out of the weather.

Note: Only qualified craftsmen licensed within the governing jurisdiction to perform the work associated with this installation should install and/or service this equipment.

UtC TOUCHSCREEN CONTROLLER MODEL NUMBERS

FIGURE 1

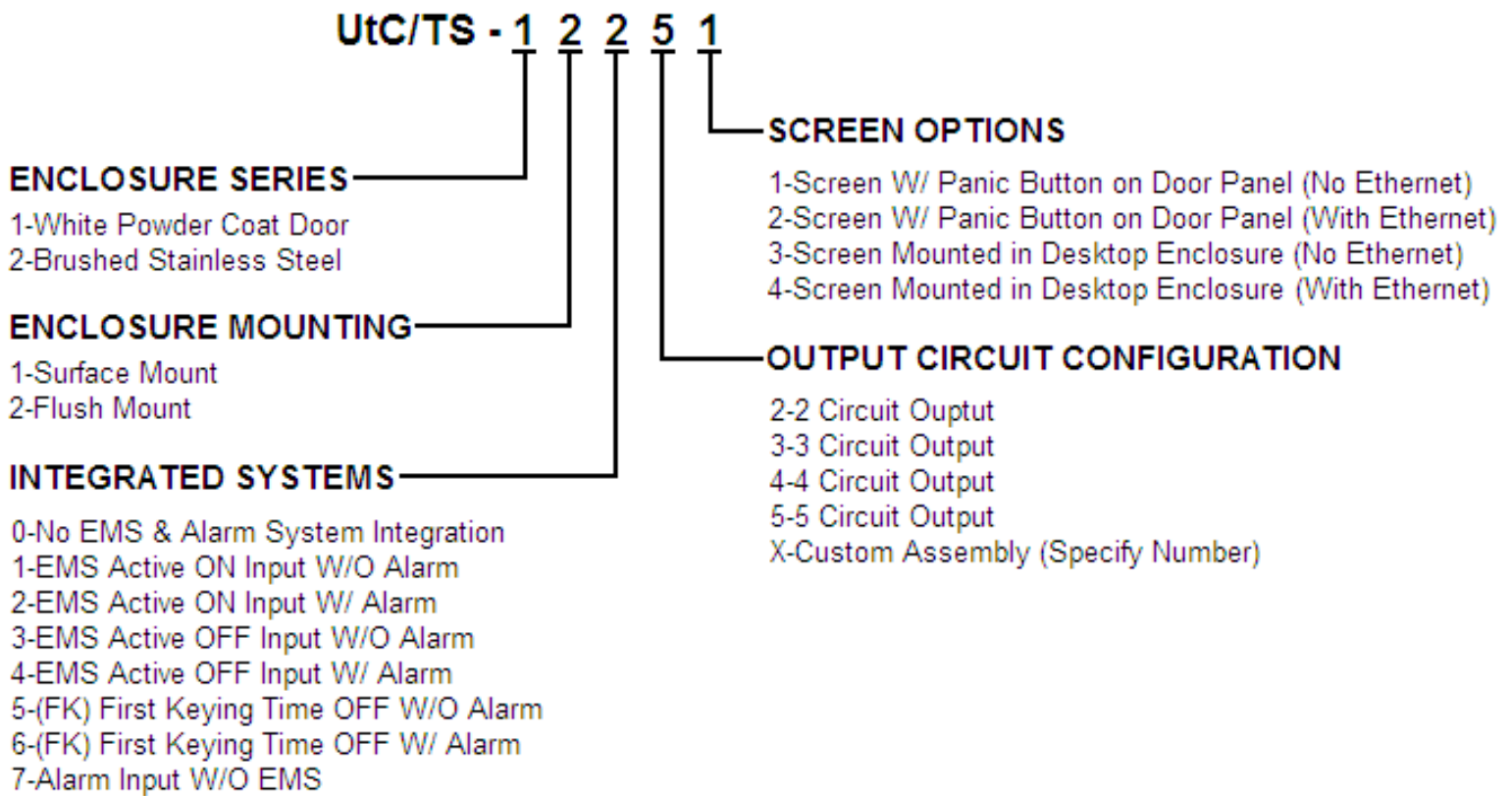

NOTE: Internal Power Supply rated at 1.3 Amps @ 24 VDC

All service outputs are only used to activate external 24 Volt control relays. When ordered with ISIMET S-Series and E-Series, relays will be provided in these enclosures.

Installing the Enclosure

There are two options for mounting the Utility Controller: Flush Mounted and Surface Mounted.

CAUTION: Provided mounting hardware must be used.

Flush Mounted

Prior to installation:

- The Enclosure mounts between two standard spaced wall studs within a minimum 4" wall cavity. (Enclosure Dimension – 16"x14"x4")
- If stud spacing is greater than that required for the mounting of the controller, add studs to ensure a secured mounting.
- The studs should be facing to facilitate securing the Enclosure.
- Predetermine wall finish so that the face lip of the enclosure aligns flush with the finished wall surface.

To install:

1. Using the self-starting screws (13), mount the flanges at each side and at the top and bottom of the enclosure.
2. Attach the enclosure to the wall studs with field-provided sheet metal screws per the drawing.
3. Level the enclosure.

Notes:

- When the Door Panel is mounted onto the Enclosure, it should protrude beyond the wall surface about 1/4". Care should be taken at installation time to ensure that this occurs.
- A Flush Mounting Trim Flange is provided with each flush mounted unit. Separate installation instructions and hardware are included with this flange.
- Semi and Flush Trim add 3.5 inches to both Height and Width wall surface dimensions.
- It is the responsibility of the installer to verify finish wall dimensions.

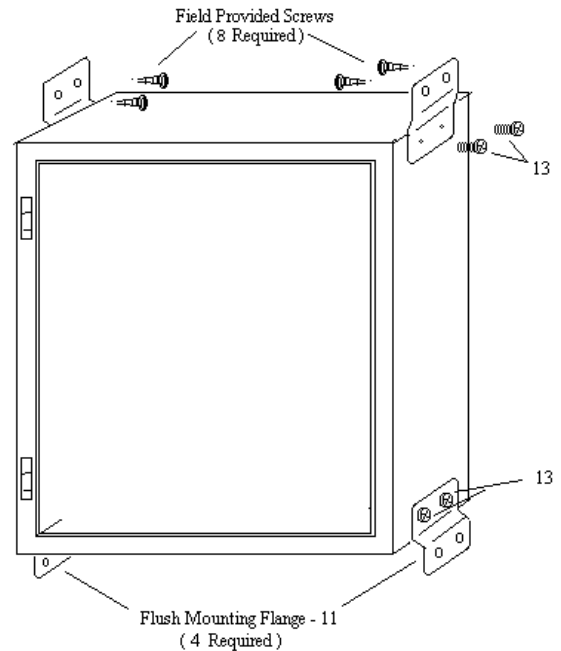

Figure 2 For best Flush Mounting results, recess face of enclosure's lip 1/2" behind wall finish

Semi-Recess Enclosure Placement Note:

For Semi-Recess Units, the face of the enclosure's lip should be positioned 1/4" beyond wall finish.

Clearance around Enclosure:

Care should be taken to allow 1/2" clearance from wall framing and sheet-rock or other wall surface material around the outer surface of the unit to permit the trim to be properly installed.

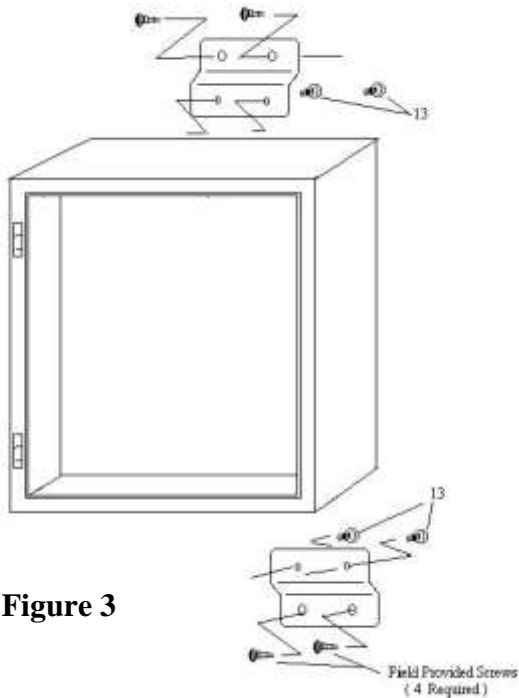

Figure 3

Surface Mounted

Prior to installation:

- Wall finishes should be complete.
- The wall cavity must have sufficient backing or support to ensure a firm mounting of the enclosure to the wall surface.

To install:

1. Secure the surface mount flanges to the back of the enclosure with the self-starting screws (13).
2. Use the field-provided screws to attach the enclosure by the flanges to the wall surface.
3. Level the enclosure.

Installing the Electrical Conduit

Only one Knock-Out is provided from the factory on the top left corner of the Utility Controller.

- Connect rigid conduit for the required 120 VAC electrical service at the top left as indicated in Figure 4.
- Conduit holes for wiring to Terminals 1 & 2 may be made on the top, bottom, or right side of the enclosure.

Important!

- **All local codes must be followed when connecting the conduit to the service panel.**

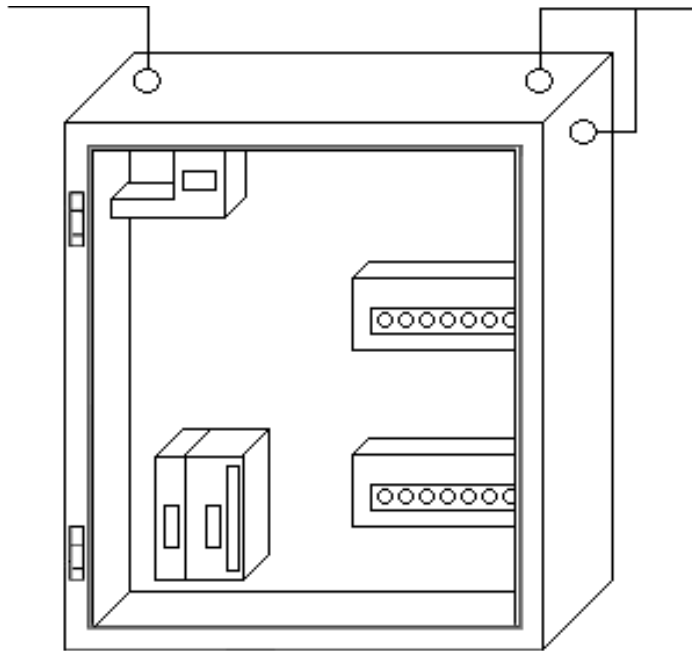

Figure 4 – Controller Knock-out

Wiring the Utility Controller

Important!

Verify that the electrical supply is disconnected prior to connecting wiring to the Utility Controller.

To wire the Utility Controller:

1. Remove the junction box cover from the panel surface.
2. Make final connections to the 120 VAC electrical service to wiring within the junction box. Verify that line wiring (Black), neutral (White), and ground wire (Green) are correctly connected. Minimum recommended wire size is 14 AWG.
3. Replace the junction box cover before activating or testing the unit.

Figure 5 - Junction Box

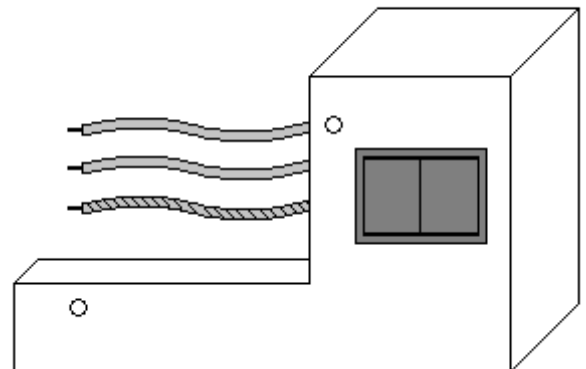

Installing the Door Panel

Figure 6

To install the Door Panel on the Enclosure:

1. Position the door at 90° – 100° of enclosure. (STEP 1)
2. Slide top hinge pin onto fixed hinge post at top of door. (STEP 2)
3. Slide lower hinge pin toward lower spring hinge mechanism with hinge pin lever in retract position. (STEP 3)
4. With lower hinge pin in position, turn hinge pin lever outward and down, then turn inward to the extend lock position. (STEP 4)

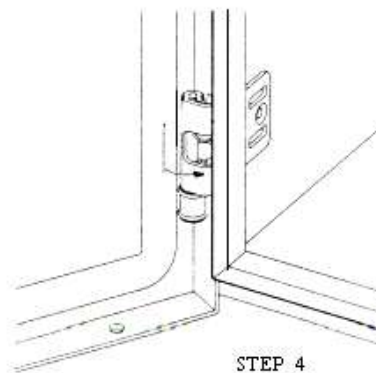
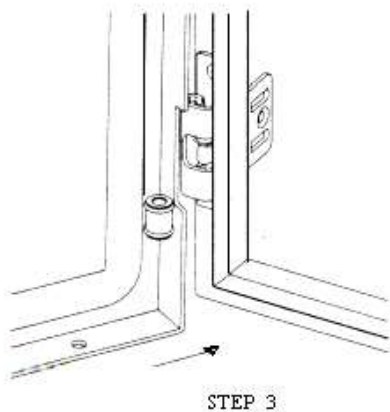
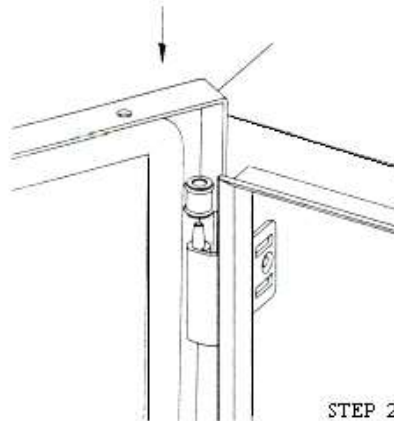
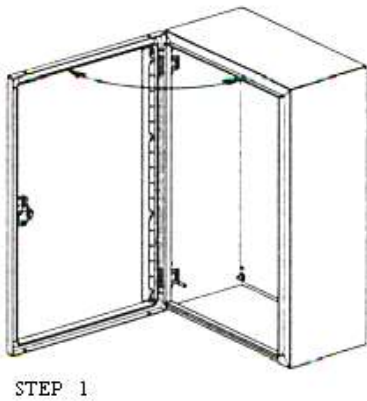

Installing Flush Door Trim

Figure 7

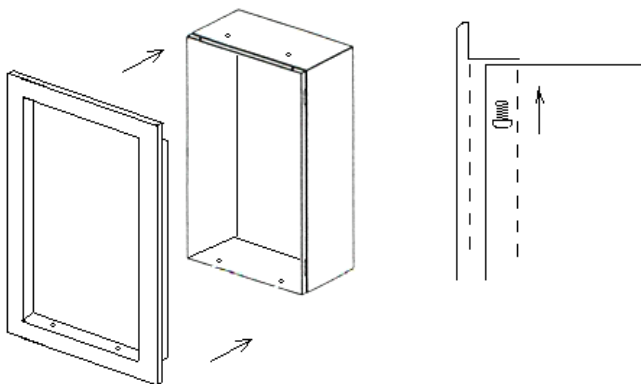

Prior to installing Door Trim, ensure that wall finishes are complete and that the door panel has been installed.

To install the Flush Door Trim:

1. With the door in the open position, slide flush door trim over enclosure. See Figure 7.
2. Align holes on enclosure with upper and lower holes in door trim.
3. Insert four (4) 12-24 (provided) screws through enclosure panel and tighten into door trim.

Notes: Holes in enclosure are slotted to allow installer to adjust trim to wall finish.
Flush Trim adds 3 ½" to both Height and Width of Wall Surface dimensions.

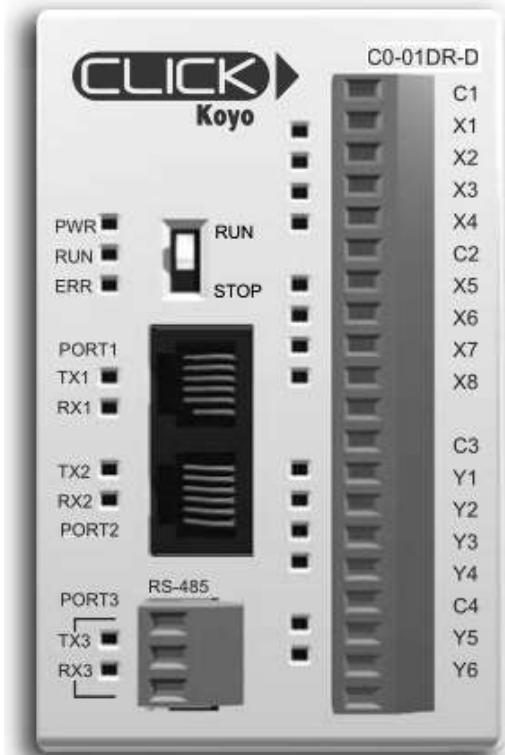

PLC Overview:

Each UtC/TS Utility Controller is equipped with a Micro-PLC to control all of its functions.

The PLC comes programmed and wired from the factory and should not be altered in any way.

Note: All units will be shipped with the PLC Mode switch in the STOP position. It should remain in this position until Start-Up testing is going to be performed. Once ready to test the system, the switch must be set to the RUN position for the controller to function.

Indicator Light	Description of Status When Light is On
PWR	PLC has 24VDC from Power Supply
RUN	PLC is set to RUN Mode and is operational
ERR	PLC Processor has incurred an error
X1	Door Panic Button is being pressed
X2	Remote Panic signal being received (Dry-Contact)
X3	Alarm signal being received (Dry-Contact)
X4	EMS signal being received (Dry-Contact)
X5	EMS signal being received (24VDC)
X6	Not Used
X7	Not Used
X8	Not Used
Y1	Circuit 1 active (Electric)
Y2	Circuit 2 active (Gas)
Y3	Circuit 3 active (Hot Water)
Y4	Circuit 4 active (Cold Water)
Y5	Circuit 5 active (Fan)
Y6	Panic Output active

Table 1

Connecting Controlled Utility Services

The Utility Controller is not provided with electrical solenoids, contactors, or relays. *ISIMET* provides a full line of Companion Enclosures and fittings. It is recommended that these items be included in the system design, but when the installer elects to provide these fittings from other sources, compliance with product specifications must be confirmed prior to installation. The unit is equipped for 24 VDC output for control of the devices. Connect wiring for these devices to Terminal 2 at designated posts. All output circuits use a Common and a designated output terminal post.

NOTE: Place relays and solenoids in areas that are easily accessible for future maintenance.

Touch Panel Switch to Terminal 2 Configuration: (typical)			Terminal 2
Typical Usage	Service Switch	Standard Application	
-24VDC		Negative (Common)	Post 1
Electric Service	Switch 1	Circuit 1	Post 2
Natural Gas	Switch 2	Circuit 2	Post 3
Hot Water	Switch 3	Circuit 3	Post 4
Cold Water	Switch 4	Circuit 4	Post 5
-24VDC		Negative (Common)	Post 6
Purge Fan	Switch 5	Circuit 5	Post 7
Panic Output	Door Panic Button	Panic Output	Post 8

Note: Use of primary outputs may be changed to accommodate specific project requirements. Where only two primary outputs and purge fan are included in the assembly then the purge fan circuit replaces the third standard output. The logic code is modified to accommodate this change.

ISIMET Applications use low pressure differential / low wattage normally closed solenoids for piping systems. If solenoids other than those provided by *ISIMET* are used in the application, it is **STRONGLY** recommended that only this type of solenoid be provided. Additionally, it is recommended that if compliance with product specifications is not factory certified then operating power for the solenoid should be provided from sources other than the Utility Controller.

ISIMET Applications use mechanically held Square D Multi-pole Lighting Contactors to control the 120 VAC circuits to the convenience outlets. Square D - Definite Purpose Contactors are used when a controlled device load demand exceeds normal operating amperes. All E-Series Companion Enclosures are equipped with an interface relay to enable the Utility Controller's output circuit to operate the contactors. If relays or contactors other than those provided by *ISIMET* are used in the application, it is **STRONGLY** recommended that only this type of contactor be provided. Additionally, an interface relay will need to be provided to insure compliance with application installation requirements.

Connecting Alarm and Monitoring Wiring

Alarm Input / Output

- The unit will operate without an "Alarm" input signal.
- Providing an input signal from the Alarm System at Terminal 1 will disable the Controller upon a fire alarm.

Auxiliary Panic Input

- Optional Panic Input posts are available. One or more *ISIMET* Remote Panic Buttons can be connected in parallel. This terminal point transmits a 24 VDC signal that is returned to the PLC when the remote panic is pressed.

Start-Up Checklist:

A separate Start-Up Test Sheet is provided with the installation CD. The tests described herein and in those procedures should be followed prior to placing the unit into operation. If you do not have on hand this CD and/or Start-up sheet, you may retrieve a copy from your local factory representative.

Caution!

- **Verify that ALL installation procedures and Line Voltage, EMS, Alarm, Remote Relays, and/or Solenoids conform to Equipment Specifications.**
- Examine electrical wiring at junction box to verify that ALL wiring is correctly connected.
- Examine **Terminal 1** and **Terminal 2** to assure that wiring has been properly connected. Test Output circuits at **Terminal 2** to verify that field wiring or connected devices are wired correctly. A direct short or input voltage at the output circuit will cause damage to the PLC and Controller.
- Verify that the Door Panel plug is firmly secured to its terminal and ground wire is connected.
- Examine Door Panel factory wiring to ensure that it was not damaged or loosened during shipping or installation.
- If unit is integrated with “EMS”, verify that wiring is installed at correct terminal posts. Verify that input voltage conforms to unit specifications.
- If unit is integrated with an alarm system, verify that wiring connections, voltage requirements, and alarm system conform to unit specifications.
- Remove all dust and construction debris prior to proceeding.

Start Up Test Preliminary Information

Caution!

- Do not proceed with equipment start-up until the Start-Up Checklist has been completed.
- Before commencing these Start-Up tests, turn the control switch to the **OFF** position.
- If the unit is integrated with a monitoring system, disconnect wiring from posts “Panic Output” at Terminal 2.

This unit was factory tested, but the manufacturer recommends that the installer perform these tests to ensure that the unit did not sustain damage during shipment or installation.

- Perform Start-Up Tests with the Door Panel open.
- With the control switch **ON**, “PWR” LED on the PLC should illuminate. If not, check circuitry for 24VDC power at Power Supply.
- If after performing these tests and verifying operation, if the Unit fails to function contact an *ISIMET* factory representative.

Start-Up Tests

A. Testing the Control Wiring and Service Switches

1. Turn the control switch to the **ON** position. Voltage should read 120 VAC. If it does not, consult an electrician before continuing this testing.
2. From the System Enable Screen (Refer to Users Guide) turn the first service button to the **ON** Position.
3. The button will turn green and the corresponding LED on the PLC will illuminate.
Using testing probes, verify that the corresponding terminal posts at Terminal 2 are energized.
4. Repeat steps 2 and 3 for the remainder of the service switches.
5. Turn all service switches **ON**. All services should be **ON**. All green indicating lights should be illuminated. Verify **ALL** power loads with test probe.
6. Turn service switches **OFF**.

B. Testing the Panic and Alarm Systems

Note: (Alarm input will deactivate the unit when configured per unit specifications)

1. If the unit is integrated with a monitoring system:
 - a. Verify that the monitoring system is **OFF** or that the unit has not been fully integrated with the monitoring system.
 - b. Disconnect the wiring from Terminal 2, “Panic Output” posts.
 - c. Press and release the red panic button. **If not integrated with a monitoring system, skip the remainder of this test.**
 - d. Use test probes to check voltage at ‘Panic Output’ posts. 24VDC should be present across posts 5 & 8 while in “Panic”.
2. Press the Reset System button on the screen. Once the Passcode is entered the system is reset.
3. Re-check voltage. None should be evident.

Remote Panic Assembly: The unit will accept integration of an *ISIMET* Remote Panic Assembly. If one is provided, wiring connections can be made at Terminal 1. Directions are provided with that remote assembly.

C. Testing the “EMS” and alarm Input signals

The unit has been factory tested to assure that both “EMS” and “alarm” Inputs perform correctly. Field verify that wiring to Terminal 1 is connected to the proper posts.

D. Testing the Building’s Utility Systems

1. Turn **ALL** control switches **ON**.
2. Field-test **ALL** utility and appliance outlets to confirm that services have become active.
3. Turn the switch for each utility to **OFF**. Verify that the specific utility outlets are not active or “**ON**”.

E. Test Completion

The unit should now be fully operable. If it is not, contact an *ISIMET* Service Representative.

1. Turn the Control Switch **OFF**.
2. Reconnect **ALL** integrated services.
3. Replace **ALL** panels and covers.
4. Turn the Control Switch **ON**.
5. Close and lock the Door Panel.

Equipment Operation

Note: The Utility Controller should be operated by an instructor possessing only the Passcode. Once the unit has been thoroughly tested, the installer should provide keys for the unit on separate rings to the property owners, administrators or their representatives. The Utility Controller is intended to function as a control system for the utility services and devices located within the room. The Passcode provides for security against unauthorized use of the services.

CAUTION: Having outlets such as Gas Turrets Open when Services are activated can result in injury or death. Verify that these outlets are closed prior to activating the unit.

To Activate One or More of the Services Controlled by the Unit: (Refer to Users Guide)

1. From the Home Screen press Start System button.
2. Enter Passcode.
3. Turn **ON** corresponding switch for the service you wish to activate.

To Turn a Service OFF:

Turn the appropriate switch to **OFF**. It is not necessary to enter Passcode.

Note:

- A service left **ON** remains **ON** until its switch is turned **OFF** unless the Panic button is depressed, System Shutdown is pressed, or line voltage is removed from the controller.

To Activate the “Fan” Circuit (Optional):

Upon Panic, the Fan will automatically turn **ON**, and upon an “alarm” Input will automatically turn **OFF**. If the Fan circuit is set with Fan Timing Feature then whether the Fan is operated by switch or Panic, the Fan will turn **OFF** at end of timing cycle.

In Case of an Emergency:

Press the red panic button on the door panel. This will disable the panel and **ALL** services. If the unit is integrated with building monitoring systems, a Panic signal will be sent to that system. Once the panic button is pressed the Passcode must be re-entered to reset from panic. Also, the Panic Screen will remain on until reset is accomplished.

If You Cannot Activate the Services:

The screen will tell if one of these signals is present: There may not be an electronic signal from the building “EMS” (Energy Management System); there may be an “Alarm” signal from the building alarm system; there may be an Isolated Panic Signal from an integrated system; or the system may be in the “panic” state. When the unit is integrated with either the “EMS” and/or the Alarm system, a second level of security is in place because, without an electronic activation signal from the “EMS” or lack of signal from the Alarm, the unit **WILL NOT** function. Unauthorized access to the services is prevented during times when the building or classroom is normally unoccupied. However, if room air conditioning or heat is operational, the unit should function.

At the End of the Day:

ISIMET recommends that the System Shutdown button be pressed prior to exiting the room. The unit, when integrated with an “EMS”, provides a secondary safety feature that automatically turns **OFF** any services left **ON** at the end of the “EMS” cycle.

Troubleshooting Guide

If the Utility Controller fails to energize, follow these procedures:

- Verify that the Controller has correct line voltage connected. With the control switch in the **ON** position, the PLC “PWR” light should be illuminated. If it is not, check the wiring connections. Remove the wiring junction-box cover and examine wiring connections.
- Verify that Touchscreen turns on and initializes.
- Touchscreen should start-up on the Home Screen.(Refer to Users Guide)
- Verify that PLC Mode switch is set to “RUN” position.
- Verify that the Door Panel plug is securely connected to the door terminal.
- Check the wiring terminals on the door panel to verify that none has become damaged or disconnected during installation. Reconnect, if necessary.

If services do not turn on with switches:

1. Verify that PLC Mode switch is set to “RUN” position.
2. Verify proper voltage at corresponding posts on Terminal 2.
3. If you do not read the correct voltage at the terminal posts, contact an *ISIMET* Service Representative.
4. If you read the correct voltage, test the remote relay and/or solenoids to verify that they are operational.

In many cases, failure of the system is the result of improper connection of a remote service or device such as a remote relay, solenoid, “EMS”, or building alarm. Refer to **Equipment Specifications** to confirm that correct connections to these services and devices have been made.

Notes:

- Damage to the Electronic Controller and other components can occur from improperly connecting the services, overloading the output circuits, or failing to follow all start-up tests and checklists.
- In ALL cases, if the system fails or you have questions about the equipment, contact an *ISIMET* Service Representative.
- If the results of all test procedures are positive but utilities will not activate, *ISIMET* recommends that you examine and test the various utility services controlled by the unit to verify that they are operational and active.

CAUTION: The output circuits of the Controller provide 24 VDC control signals to relays to activate and engage the various utilities. ISIMET provides a full line of Companion Enclosures and fittings. It is recommended that these items be included in the system design, but when the installer elects to provide these fittings from other sources, compliance with Product specifications must be confirmed prior to installation.

If utilities or controlled devices remain operational after the service switch is disengaged, check for the following before placing the unit into full operation:

- A defect in the remote relay or solenoid
- Tampering
- The remote relay unit has a control switch with a manual operation position and the switch is in the manual position.

If utilities or devices continue to be active or if you have a question about the operation of the unit, contact an *ISIMET* Service Representative immediately.

Equipment Maintenance

- ❑ The Utility Controller should have semi-annual inspections.
- ❑ *ISIMET* recommends opening the service panel and turning **OFF** the control switch prior to long periods of inactivity in the building.
- ❑ Prior to anticipated activity within the building, *ISIMET* recommends that you conduct a brief test of the control system by performing Start-Up Test Procedure A and Step 1 of Procedure B.
- ❑ If examination of the unit indicates tampering, *ISIMET* recommends that you first review the Start-Up Checklist, then conduct **ALL** Start-Up tests.
- ❑ *ISIMET* recommends that the door panel key be kept in a secured location. The door panel key should be available only to those needing access to the interior of the unit for the purposes of maintenance or service. *ISIMET* recommends that the door panel remain locked unless service is performed.

If you have any questions regarding the operation and maintenance of the Utility Controller, please contact an *ISIMET* Service Representative.

The enclosure has a NEMA 1 rating. It is not intended for use in wet areas. Exercise caution to prevent exposure of the interior compartment of the enclosure to moisture. If moisture is present within the enclosure, *ISIMET* recommends that the control switch be turned **OFF**, power be disconnected from the unit until the source of the moisture is determined, and all moisture is removed from the compartment.

The electronic controller (PLC) is sensitive to moisture, dust, debris and other air-borne particles. Do not expose the interior compartment of the enclosure. During the semi-annual inspection, if dust or other material is present, *ISIMET* recommends that you remove all foreign matter before operating the unit.

If the Unit fails to operate, we recommend that you check the power supply to the unit. With the control switch in the **ON** position, the PLC “PWR” light should be illuminated if power is on to the unit. If not, check the service breaker.

If the unit still fails to operate, we recommend that you contact your local Service Representative.

Removing the Door Panel

Before removing the Door Panel, turn power **OFF** at the control switch, then disconnect the plug from the terminal within the enclosure.

Follow steps 1 – 4 in reverse as shown in Figure 6.

Instructions for Re-coating the Enclosure

If the finish surface of the enclosure or door panel becomes scratched, follow this procedure to repair the surface.

- Most standard, good quality paints can be used to re-coat the polyester powder finish.
- For best results, correct surface preparation before re-coating is essential. Follow instructions provided by your paint manufacturer.
- Wipe surfaces to be painted with either xylene or lacquer thinner solvent.
- Allow surface to flash dry prior to painting.
- Follow paint manufacturer’s instructions for applying paint.
- Allow paint to cure adequately. Consult the paint manufacturer for proper cure time and hardness.

***ISIMET* believes that sole and local authority means that the primary operator or the instructors should have the sole authority to start and stop the utility services within the immediate area of use during normal usage. This should distinguish this type of operating environment from that where a single emergency shut-down device is located remotely from the areas of use. As an example, the *ISIMET* system is not specifically intended for use in applications where a master shut-down and re-instate device is located away from areas of normal use. *ISIMET's* opinion is that in such cases there is risk that the operator of the system during re-start may inadvertently activate utilities in an unoccupied area that is remote from the present occupancy, thus creating the risk of injury and/or fire where the utility is fuel gas.**

Additionally, the operation of emergency devices including emergency showers and eyewashes should not be integrated with this system for either activation or deactivation.

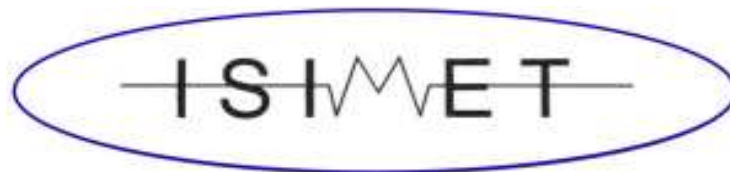

ISIMET/MAPA, LLC

**103 W. CJ Wise Parkway
PO Box 129
Naples, TX 75568**

**(903) 897-0737
Toll Free (866) 897-0737
Fax (903) 897-0740**

www.ISIMET.com

**Innovative Systems
Integrating
Mechanical and Electrical
Technology**